

MCHW series

180° ANGULAR GRIPPER - Rack & pinion style



Features:

- For applications where saving space is a necessity.
- Each one of the two fingers, synchronized by a rack and pinion, rotates back perpendicular to the gripper.
- Dust proof construction.
- Auto switch mounting at 4 locations.

Specification:

Model	MCHW				
Acting Type	Double Acting				
Tube I.D. (mm)	20	25	32	40	50
Medium	Air				
Operating pressure range	1.5~7 kgf/cm ²				
Ambient temperature	-10~+60°C (No freezing)				
Repeatability (mm)	±0.2				
Max.operating frequency(c.p.m)	60	30			
Lubrication	Not required				
Effective force (Nm) at (5kgf/cm ²)	0.30	0.73	1.61	3.70	8.27
Operating angle (both sides)	Opened side	180°			
	Closed side	-5°	-6°	-5°	-4°
Weight (kg)	0.30	0.53	1	2.2	5.15

Order example:

MCHW-25 D 1 - RK × 1

MODEL

BORE

- φ 20
- φ 25
- φ 32
- φ 40
- φ 50

D:Double acting

FINGER OPTION

Flat finger (standard)

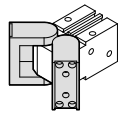

Right angle finger tap mounting.

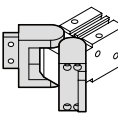

NUMBER of AUTO SWITCH

AUTO SWITCH TYPE

in-line	style
RK	Reed switch
RKN	NPN
RKP	PNP

Clamping of work

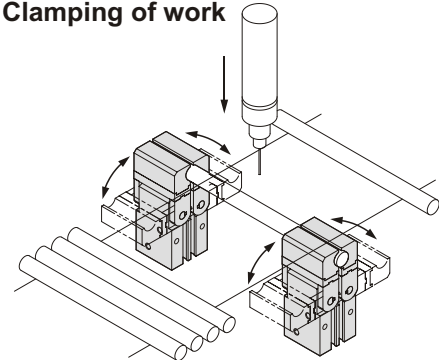

Transferring work

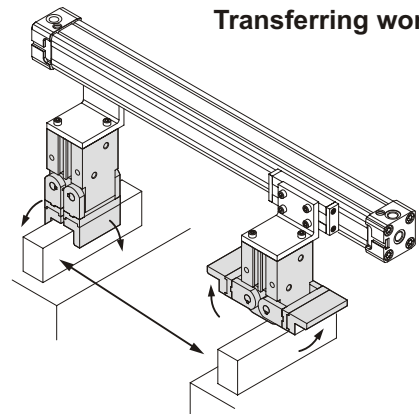

Two finger styles available

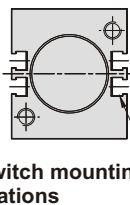
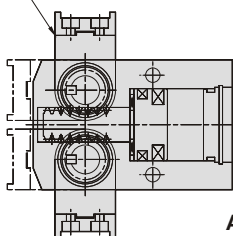

Key connection is ideal for impact resistance

Key connection between finger and shaft prevents finger angle slippage during impact.

Bearings are standard.

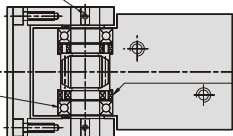

Auto switch mounting at 4 locations

Dust proof construction
seal arrangement protects gripper from harsh dusty environments.

MCHW Mounting $\phi 20 \sim \phi 50$

180° ANGULAR GRIPPER - Rack & pinion style



Mounting

Axisl mounting (body tapped)

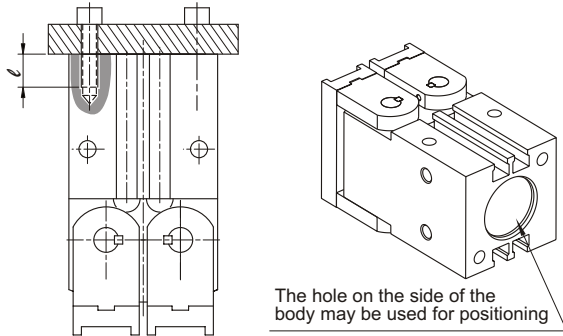

Model	Bolt	Max.torque N.m	Max.screw depth ℓ (mm)
MCHW-20	M5 \times 0.8	4.3	10
MCHW-25	M6 \times 1	7.4	12
MCHW-32	M6 \times 1	7.4	12
MCHW-40	M8 \times 1.25	17.7	15
MCHW-50	M10 \times 1.5	37.2	20

Model	Hole diameter (mm)	Height (mm)
MCHW-20	$\phi 21H9$ $^{+0.052}_{-0}$	3
MCHW-25	$\phi 26H9$ $^{+0.052}_{-0}$	3
MCHW-32	$\phi 34H9$ $^{+0.062}_{-0}$	4
MCHW-40	$\phi 43H9$ $^{+0.062}_{-0}$	4
MCHW-50	$\phi 52H9$ $^{+0.074}_{-0}$	5

Vertical mounting (body tapped)

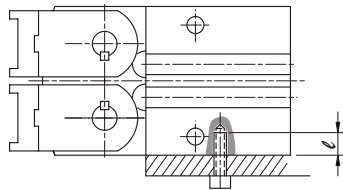

Model	Bolt	Max.torque N.m	Max.screw depth ℓ (mm)
MCHW-20	M5 \times 0.8	2.9	7
MCHW-25	M6 \times 1	5.9	10
MCHW-32	M6 \times 1	5.9	10
MCHW-40	M8 \times 1.25	17.7	15
MCHW-50	M10 \times 1.5	37.2	20

Warning

- When using right angle finger tap mounting type, pay attention the interference of bolt and speed controller.

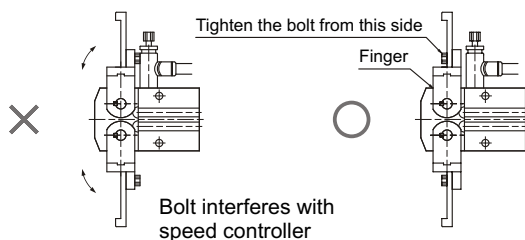

Lateral mounting (body tapped)

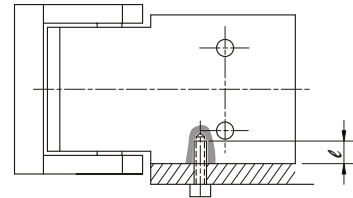

Model	Bolt	Max.torque N.m	Max.screw depth ℓ (mm)
MCHW-20	M5 \times 0.8	4.3	10
MCHW-25	M6 \times 1	7.4	12
MCHW-32	M6 \times 1	7.4	12
MCHW-40	M8 \times 1.25	17.7	16
MCHW-50	M10 \times 1.5	37.2	20

Lateral mounting (body through hole)

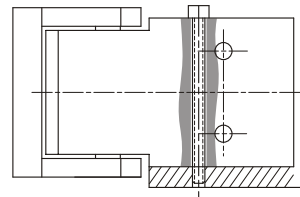

Model	Bolt	Max.torque N.m
MCHW-20	M4 \times 0.7	2.1
MCHW-25	M5 \times 0.8	4.3
MCHW-32	M5 \times 0.8	4.3
MCHW-40	M6 \times 1	7.4
MCHW-50	M8 \times 1.25	17.7

How to mount attachment on fingers

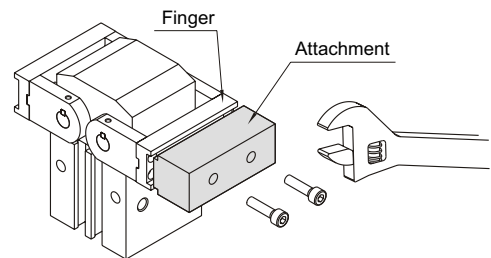

- To mount an attachment to a finger, make sure to use a wrench to support the attachment so as not to apply undue strain on the finger.
- Refer to the table below for the proper tightening torque on the bolt used for securing the attachment to the finger.

Model	Bolt	Max.torque N.m
MCHW-20	M4 \times 0.7	1.4
MCHW-25	M5 \times 0.8	2.5
MCHW-32	M6 \times 1	4.1
MCHW-40	M8 \times 1.25	10.6
MCHW-50	M10 \times 1.5	24.5

Effective holding force

Indication of effective holding force

1. Although the condition differs according to the coefficient of friction between the attachment and work, select a model that can produce a holding force of 10 to 20 times the work.
2. Further allowance should be provided when great acceleration or impact is expected during work transfer.

Ex.)

For setting the holding force to be at least 20 times the work weight;

Required holding force = $0.1\text{kg} \times 20 \times 9.8\text{m/s}^2 = 20\text{N}$ min.

When MCHW-25 is selected, the holding force is determined to be 23N according to the holding point distance ($L = 30\text{mm}$) and the pressure (5kgf/cm^2).

3. The holding force shown in the tables represents the holding force of one finger when all fingers and attachments are in contact with the work.

L: Holding point distance F: Thrust of one finger

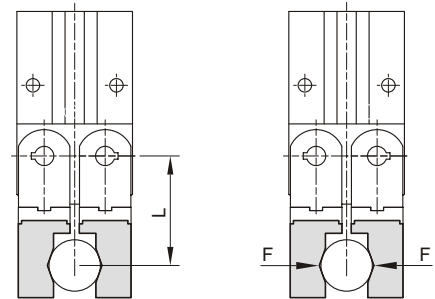

External hold

MCHW-20

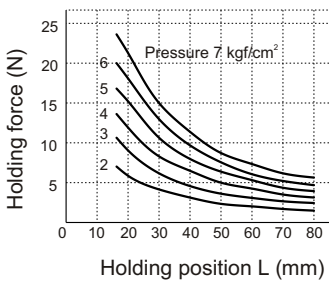

MCHW-25

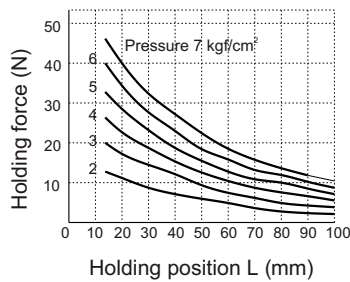

MCHW-32

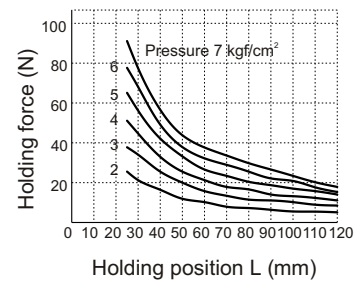

MCHW-40

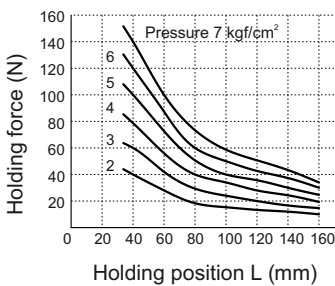

MCHW-50

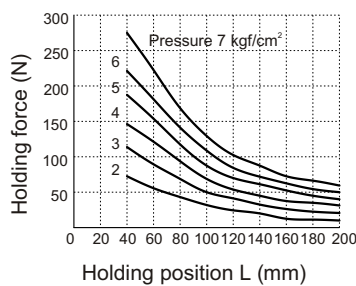

Confirmation of holding point

Work should be held at a point within the range of overhanging distance (H) for a given pressure indicated in the tables. When the work is held at a point outside of the recommended range for a given pressure, it may cause adverse effect on the product life.

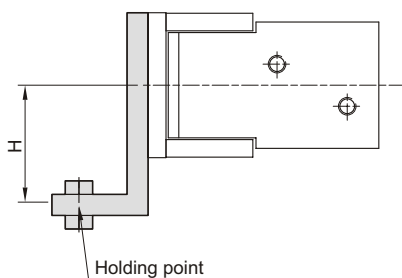

MCHW

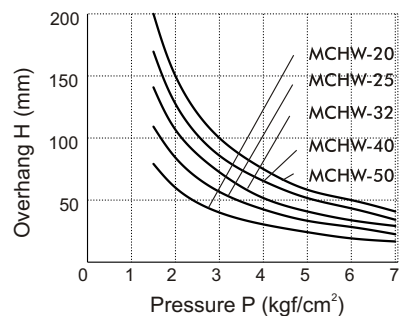

Flat finger (standard)

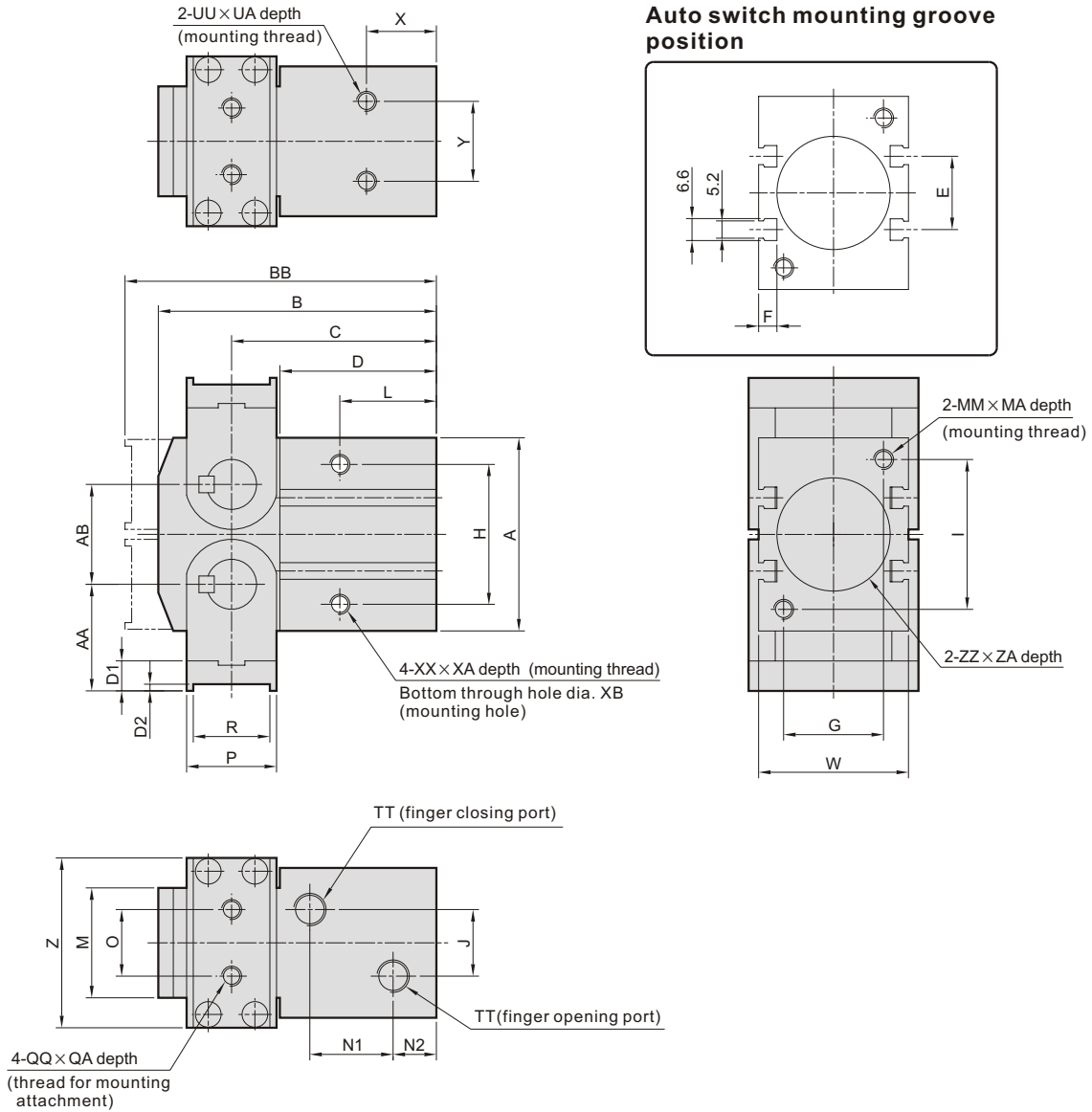

Code Tube I.D.	A	AA	AB	B	BB	C	D	D1	D2	E	F	G	H	I	J	L	M	MA	MM	N1	N2	O	P
20	36	23	18	60	68	45	35	7	2	8	5	26	27	26	12	23	30	10	M5×0.8	20	9	18	16
25	45	27	24	69	78	51	40	8	2	9	5	30	34	30	16	27	30.3	12	M6×1	23	10	20	21
32	58	32	30	83.5	93.5	61.5	47	9	2	22	5.5	30	42	45	20	29	32.9	12	M6×1	25	13	20	27
40	80	42	40	104.5	117.5	75.5	56.5	12	3	20	5	36	54	60	20	37.5	45	15	M8×1.25	33.5	14	28	36
50	112	58	56	136	154	96	69	17	4	26	5	40	70	80	30	48	58.6	20	M10×1.5	22	16	38	52

Code Tube I.D.	R	QA	QQ	TT	UA	UU	W	X	XA	XB	XX	Y	Z	ZA	ZZ
20	12 ^{+0.2} _{+0.1}	5	M4×0.7	M5×0.8	7	M5×0.8	36	17	10	4.2	M5×0.8	20	41	3	$\phi 21H9$ ^{+0.052} ₊₀
25	17 ^{+0.2} _{+0.1}	6	M5×0.8	M5×0.8	10	M6×1	40	20	12	5.1	M6×1	24	45	3	$\phi 26H9$ ^{+0.052} ₊₀
32	23 ^{+0.2} _{+0.1}	7	M6×1	Rc 1/8	10	M6×1	45	21	12	5.1	M6×1	24	51	4	$\phi 34H9$ ^{+0.062} ₊₀
40	30 ^{+0.3} _{+0.1}	9	M8×1.25	Rc 1/8	16	M8×1.25	56	27.5	16	6.8	M8×1.25	30	67	4	$\phi 42H9$ ^{+0.062} ₊₀
50	44 ^{+0.4} _{+0.1}	13	M10×1.5	Rc 1/4	20	M10×1.5	66	36	20	8.5	M10×1.5	40	85	5	$\phi 52H9$ ^{+0.074} ₊₀

Right angle finger

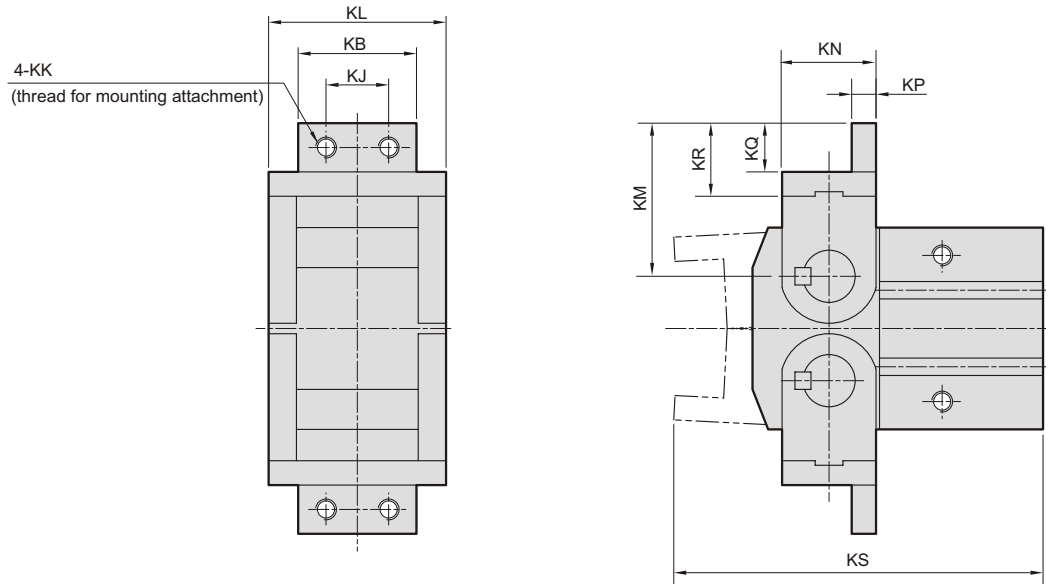

Code Tube I.D.	KA	KB	KJ	KK	KL	KM	KN	KP	KQ	KR	KS
20	5	28	14	M4 × 0.7	41	31	16	5	10	15	76
25	6	30	16	M5 × 0.8	45	37	21	6	12	18	88.5
32	7	34	18	M6 × 1	51	44	27	7	14	21	106
40	10	44	24	M8 × 1.25	67	60	36	10	21	30	136
50	12	58	30	M10 × 1.5	85	85	52	13	24	37	175